

Introduction

The following instructions describe how to install and operate the ALPHA™ On-Site Wireless Transmitter System.

NOTE: Because the ALPHA On-Site Wireless Transmitter System does NOT use the TAP protocol, it will **not** work with Smart Alec software version 2.x. However, the system will work with Smart Alec software version 1.8 and AlphaNET plus for Windows software.

Parts kit

The following items are included in the parts kit (PN 1088-1312):

PN	Qty	Description
1088-5802	1	Wireless transmitter system, 467.850 MHz
9708-8079A	1	Installation instructions

Table 1: Parts kit (PN 1088-1312)

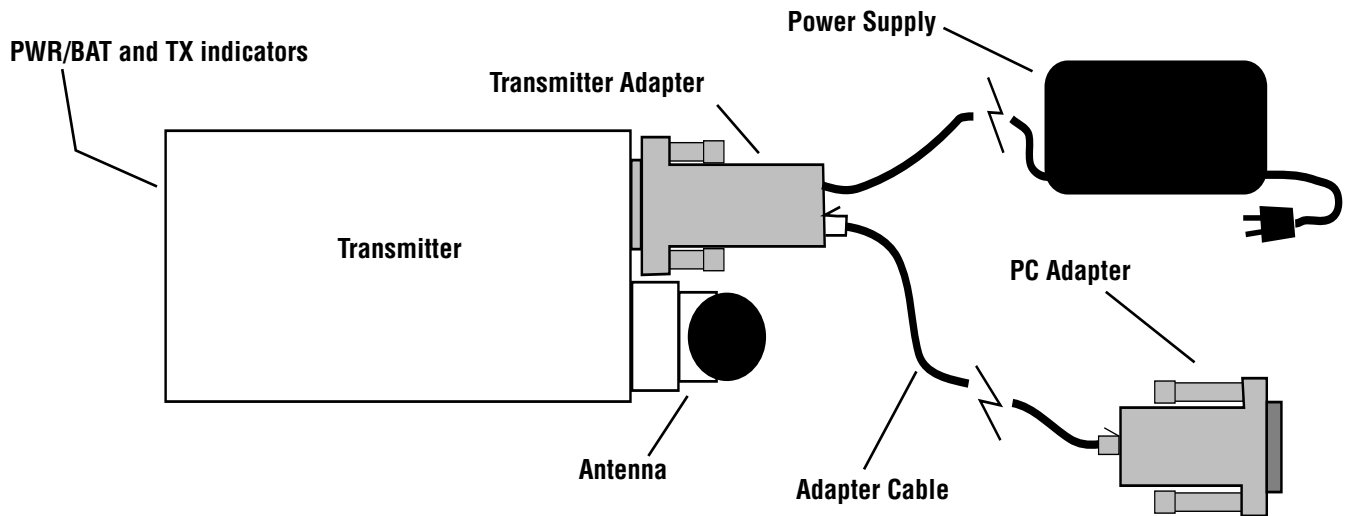

Figure 1. Parts identification of the wireless transmitter system (PN 1088-5802)

Special instructions

- In order for an ALPHA™ sign to receive messages from the ALPHA™ On-Site Transmitter System, a Data Receiver kit (PN 1088-1311) must be purchased and installed on the sign.
- For AlphaNET *plus*™ for Windows software, see “Setting up a wireless transmitter connection” (p. 17) and “Diagnostic program: Options” (p. 136) in the **AlphaNET *plus*™ for Windows User Manual** (PN 9708-8081A).
- For Smart Alec version 1.8 software, see “Setting up the system” in the **Smart Alec Installation & Setup Manual** (PN 9709-2008A).
- The above documentation is available at Adaptive’s web site: www.ams-i.com.

Special tools

None required.

Installation instructions

Refer to Figure 1 for these instructions:

1. Attach the Antenna to the Transmitter. Use the right angle bracket for positioning the Antenna. In normal operations, the Antenna should be oriented vertically to ensure a maximum transmission range.
NOTE: Always operate the Transmitter with the Antenna attached. Otherwise the Transmitter could be damaged.
2. Plug the PC Adapter into an available DB9 serial port connector on the back of your computer. If your computer has a DB25 serial port connector, then a serial port DB25-to-DB9 mouse adapter must be obtained. (This adapter is not supplied. However, it should be available at retail computer stores.)
3. Plug the Transmitter Adapter into the DB9 connector on the Transmitter. Then tighten the screws on the Transmitter Adapter.
4. Use the Adapter Cable to connect the Transmitter Adapter to the PC Adapter.
5. Plug the Power Supply into a 110 VAC power outlet. The red **PWR/BAT** indicator on the Transmitter should be illuminated.
6. If you have not already done so, install AlphaNET *plus*TM for Windows or Smart Alec software on your computer. Make sure the proper serial port settings are defined and that messages are addressed to the appropriately configured ALPHATM signs. During a message transmission, the green **TX** indicator on the Transmitter should illuminate.

Checkout procedure

Power

When the Transmitter is assembled and power is applied, the red **PWR/BAT** indicator on the Transmitter should be illuminated. If it isn't, verify that all connections are tight. Verify that 110 VAC power is available at the power outlet. If connections are tight, power is available and the red **PWR/BAT** indicator does not illuminate, determine if the Transmitter Adapter is at fault by trying another Transmitter Adapter. If the Transmitter still does not respond, it should probably be replaced.

Transmitter

When you send a message from the PC to the Transmitter, the green **TX** indicator on the Transmitter should illuminate briefly to indicate that transmission is occurring. If you do not receive a message on the selected sign, follow the checklist below:

- Does the ALPHATM sign have power?
- Is the red LED illuminated on the Data Receiver that is connected to the ALPHATM sign?
- Are sign addresses used in messaging? If so, you must use the correct address of the sign.
- Are the sign and Data Receiver located *at least 10 to 15 feet away* from the Transmitter during transmission? (Some Data Receivers do not properly decode paging messages when the Data Receivers are located too close to the Antenna. Holding a distance of *10 - 15 feet away* from the Antenna is usually sufficient to allow the Data Receiver to properly decode a transmission.)
- Is the Antenna attached to the Transmitter?
- Does the Data Receiver that is connected to the ALPHATM sign have the same frequency as the Transmitter?
- Has a correct Capcode been used? (The standard Capcode is **0102000**.)